



...NT TO OPTIMIZE PRODUCTIVITY ROBUST EQUIPMENT TO OPTIMIZE TMR MIXERS

TMR MIXERS



FEED BETTER



HURRICANE AUGER

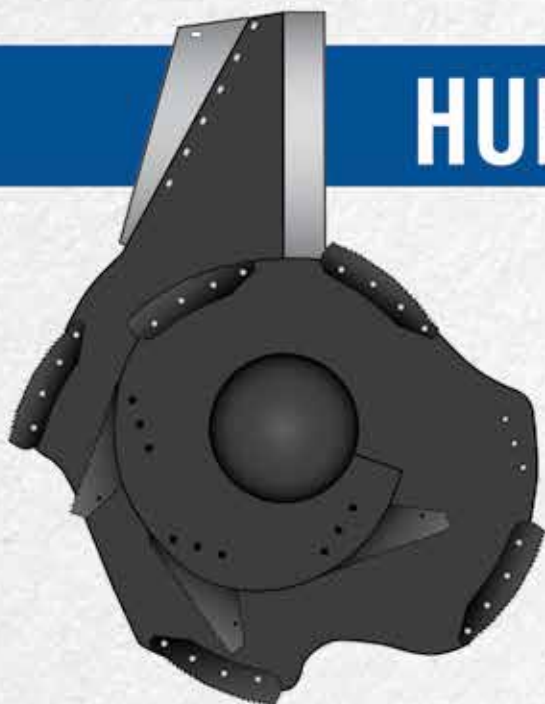

SHAPE YOUR MIX

The largest challenge facing a TMR mixer is the ability to process forages with a variety of supplements such as salts and fine minerals. This process can prove to be time consuming and costly. Our patented Hurricane auger has been designed to produce better mixes by allowing forages to circulate faster through the mix, resulting in quicker processing and mixing times.

Penta Hurricane augers are equipped with patented cut outs that allow material to drop through the auger. The falling action complements the regular motion of the ingredients being rotated throughout the tub. This combination of mixing actions has proven effective in producing more consistent mix.



CONVEYOR SYSTEMS

Optional conveyors are configured to match the needs of your individual operations with a choice of either a Flip-Up or Dual configuration. Built for long life and dependability, each system is equipped with C188 chain, the heaviest cast chain in the industry. This chain is driven using a very powerful North American made hydraulic motor.

Flip-up conveyors are configured for either left or right hand delivery, allowing you to reach up and out to get the feed into bunks. Our standard conveyor includes a stainless steel pan. This can be upgraded to include stainless pan and rails. We offer many available options to customize these conveyor systems to feed into a variety of bulks and feed alleys.

Cast Steel C188 Chain

EYE OF THE STORM

One look at our Hurricane augers and you will see their strength and power. Critical to our auger design is durability. With high-intensity forces encountered in the initial stages of cutting, the metal blades of the auger are subjected to severe pressure as the turning motion begins and the feed ingredients are pushed upwards. From the 3/4" steel that is cold pressed into shape for our flighting, to the massive 3/8" thick tube, the flighting is expertly welded. Developed over years of testing and design, you can clearly see this is our best, most rugged and reliable auger yet.

The angle and diameter of the flighting are designed to work with the tub for the best mixing and processing of your ration. The pyramid shape of the Hurricane auger reduces pressure on the system's moving parts, dispersing the forces through the body of the auger and prolonging the life of the blades. Our unique design ensures maximum blade contact with fibrous raw materials to make the cutting process rapid and complete. The high-wear stainless steel lead edge on the sweep has virtually no gap at the floor, dramatically reducing horsepower and providing excellent clean out. The bolt-on stainless steel plow blade keeps material from building up on the sides and turns material for even more mixing action.

As always, Penta continues to offer an alternative auger for the processed feed. The Tornado auger is still one of the best in the industry that mixes processed feed consistently. The results in the shaker tests show a great mix without over processing feed to increase productivity.



Stainless Steel Bolts



Wear Indicator

Stainless Steel Leading Edge

KNIFE OPTIONS

Penta augers are equipped with 3 different styles of deep serrated, heat-treated, tungsten carbide knives. Different knife styles and mounting options give you the flexibility to process any type of feed (hay, haylage, silage, straw, by products, corn, and soybean stalks), making Penta mixers the best option for all operations, delivering results no matter what your nutritional needs.





PLANETARY DRIVES

Our drives will process any type of feed, from hay to silage to corn and soybean stalks. Your PTO power is transferred to the drives through a two speed gear box for optimal mixing and a faster, more complete clean out. Our single auger mixers use the corner planetary gear box to drive the auger, backed by our standard 3 year warranty. Our Twin and Triple auger mixers use our heavy duty planetary gear box designed and built to our specifications and backed by a 5 Year Warranty.

The North American engineered gear box is able to be used in most mixer models. This box allows flexibility to run 1000rpm or 540rpm. The key is to reduce the heat buildup in the mixing process. The 2 part design allows heat to dissipate in the lower t box before transferring to the planetary.



OIL RESERVOIRS

Our high-visibility oil reservoirs are located as close as possible to the gear boxes for the best performance, ease of use, and maintenance. The high quality reservoirs are crystal clear for the easiest visual checks on oil level. On our multi-auger mixers, the reservoirs are nestled between the augers for even greater visibility and protection. We use only full synthetic oil that will not break down during temperature fluctuations.

DRIVELINE

Our PTO shafts deliver power to the mixers through all splined connections. This is the most efficient and reliable way to transfer power from your tractor to the mixer. Providing protection to our shafts are standard shear bolts. The shear bolts provide simple, straightforward protection for your equipment.



OVER PASS

Designed to give you a platform to monitor and evaluate the progress of your mix, our viewing platform provides much more. With access from the left and right of the mixer, not only is it easier to get where you need to be, but you also have a safe passage from one side of the machine to the other without going all the way around. Built into the design are hand holds and mounts for oil reservoirs on single auger and scale mounts.

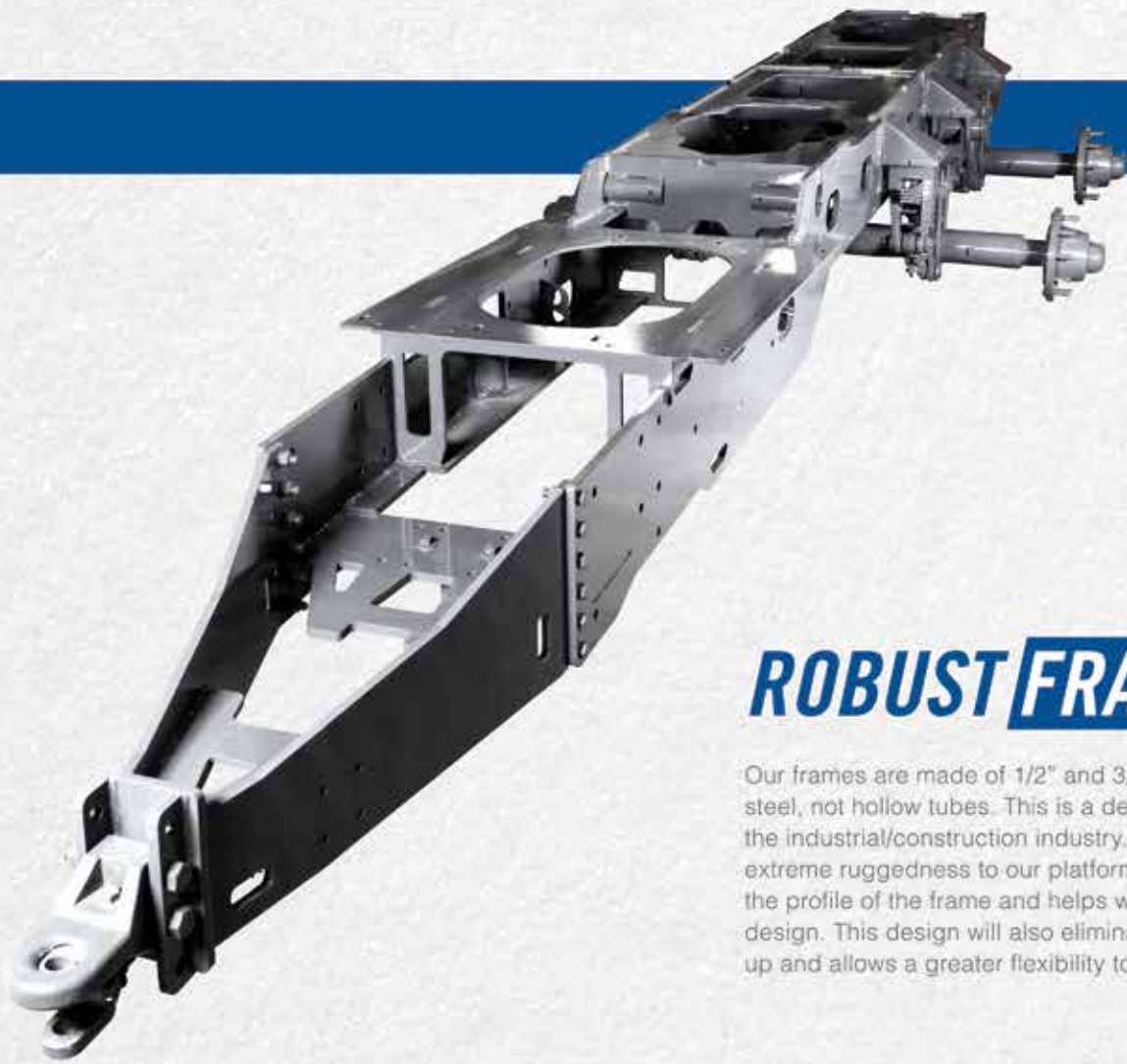

ROBUST FRAME

Our frames are made of 1/2" and 3/4" North American steel, not hollow tubes. This is a design borrowed from the industrial/construction industry. This provides not only extreme ruggedness to our platform, but also cuts down on the profile of the frame and helps with our clean, compact design. This design will also eliminate any condensation build up and allows a greater flexibility to add component options.



SUSPENSION

Our 600/cu ft and up models come with an off road suspension, reducing wear and tear on the tractor and mixer.

We use only high quality, non-imported bearings in our axles. In addition there are different configurations that can incorporate brakes and steering options.



DESIGNED PRODUCTIVITY

*The option to order
with 3/8*

Our straight walled tub is designed to reduce the compaction of your feed and will minimize over processing by allowing more room for the material to aerate. The floor of the tub is subjected to high abrasion and heavy impacts. To ensure our mixers will endure long hours of extreme use, the floor is constructed out of a solid piece of 3/4" 44w high wear, acid resistant steel. The angled curve of the tub and baffles are designed to work with our Hurricane augers for the best mix possible and provide an easy clean out. These tub ends are roll formed and then robot welded for a smooth, consistent curve that resists material build up and has an incredibly strong bond to both sides. All the tubs can be manufactured with a stainless steel liner that will give on average, 10 years of life to mixers that operate in very wet feed conditions. Liners are installed 30" high to ensure maximum protection.



MASSIVE DOORS

For the most efficient unloading and complete clean out, our front and rear material doors are 44"-48" wide on all models.

ACCESSORIES

Additional accessories are available for our TMR tubs, frames, drivelines, conveyors, and scales. There are multiple configurations and options available for each accessory. Please go to our website for further details at www.pentaequipment.com or contact your local Sales Representative.



TUB

- Rubber Extensions; 9", 16"
- Splitter Valve for Extra Hydraulic Functions
- Extra Feed-Out Doors
- Stainless Steel Tub Liners
- Extra Commodity Doors
- Rear View Camera
- 1/4"
- 3/8"

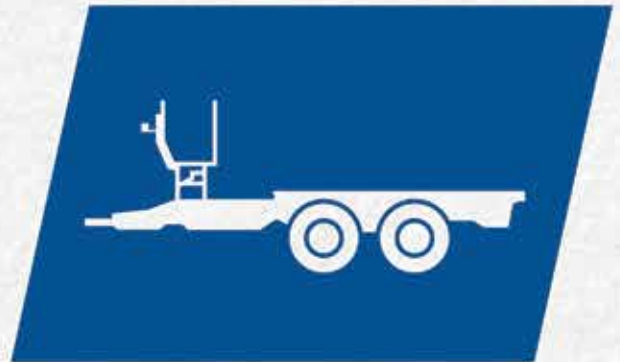

FRAME

- Light Kit
- Walking Beam
- Hydraulic Jack
- Brakes
- Hitch Options
- All Radial Tires (Flotation/Highway/Lugger)
- Axle (single/double)
- Certified Safety Chains

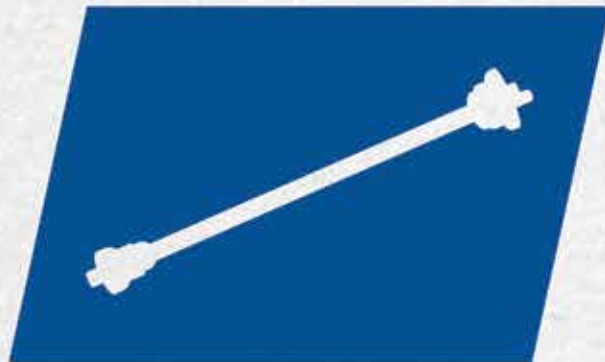

DRIVELINE

- CVPTO
- 2-Speed Gearbox
- 2-Speed On-The-Go Shifter
- 2-Speed in Cab Options
- Torque Limiter
- Auto Greaser

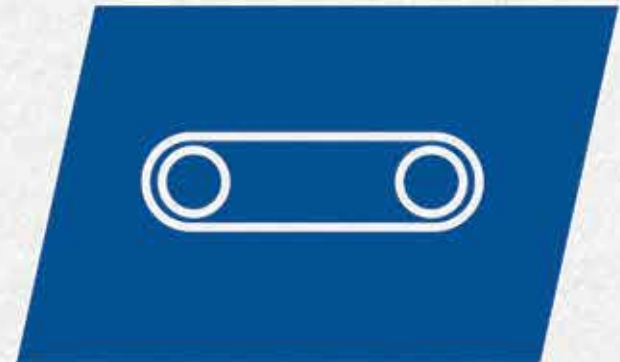

CONVEYOR

- Manual and Hydraulic
- Mudflap/Tray/Chute
- Multiple Magnet Options
- Hydraulic Chutes
- Feed Control Rubber Flaps
- Conveyor Wiper
- Stainless Steel Upgrade

SCALES



EZ2810

Simple, Durable, and Easy-to-Use

Provides basic weighing system functionality

- Preset Weight function provides improved accuracy and management of loading and unloading
- Internal “alarm light and horn” alert operator of approaching target preset weights
- Rotation Counter/Timer, a Digi-Star exclusive, significantly aids in controlling mix time and processing
- Machine Hour Meter records total operating time and Maintenance Message for service reminder functions (when used with Rotation Counter)



TMR3610

Feed Management Indicator

Advanced full management capability and USB or RF DataLink™ bi-directional data transfer.

- Program rations at your PC or from the front panel of your indicator
- Compatible with TMR Tracker® Feed Management Software and third-party bunk read programs
- Make “pen call weights” and “head count” changes at the indicator
- Keeps up-to-date feed changes or reuse data from day-to-day



WIFI CAB CONTROL

Wireless Remote Display & Control System

- Wireless communication and operation of all indicator functions on the feed mixer
- View of weight and information not affected by rain, snow, dirt or darkness
- No need to leave the loader cab during loading
- Available Ranges of 300', 1000', and 2000'
- Communicate with up to 24 different mixers
- Easily view and control scale indicator display remotely from an Android or iOS Smartphone or Tablet

TMR Tracker™

TMR TRACKER SOFTWARE

TMR Tracker is a full-featured Windows® based feed management system. TMR Tracker also offers operators additional management tools including: operator control, pen review, online feed data exchange with nutritionists, ingredient tracking and numerous reports. TMR Tracker is an indispensable management tool for forward thinking operations!

Advantages Include:

- Feed cost management
- Increase production through consistent feeding
- Promotes efficiency
- Ease of use
- Feed mixer maintenance management
- Individual operator control

SINGLE AUGER

3030



Specifications	Imperial	Metric
Capacity 9" Rubber	355 cu ft	10 m ³
Minimum Horsepower	50 HP	-
Total Width	92 in	234 cm
Total Length	221 in	561 cm
Total Height	104 in	264 cm
Loading Height	99 in	251 cm
Empty Weight	7,910 lbs	3,587 kg

Corner Door Unloading Height	Imperial	Metric
Without chute	25 in	64 cm
With chute	20 in	51 cm

Unloading Heights							
Dual	Fixed Incline	2'	3'	4'	5'	6'	7'
28"	36"	41"	49"	54"	60"	65"	70"

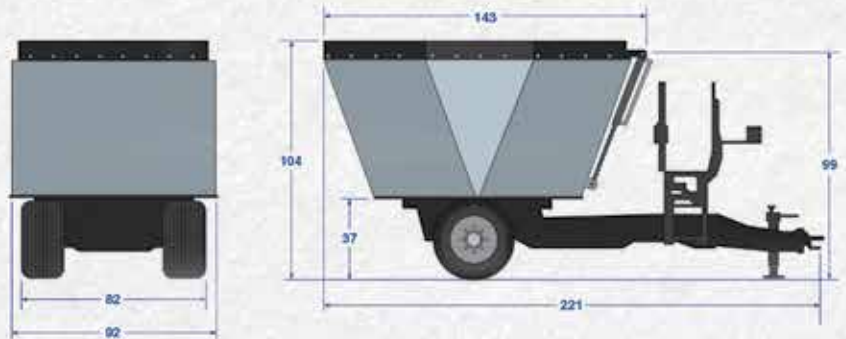

4030



Specifications	Imperial	Metric
Capacity 9" Rubber	390 cu ft	12 m ³
Minimum Horsepower	85 HP	-
Total Width	105 in	267 cm
Total Length	233 in	592 cm
Total Height	97 in	246 cm
Loading Height	96 in	244 cm
Empty Weight	9,100 lbs	4,128 kg

Corner Door Unloading Height	Imperial	Metric
Without chute	26 in	66 cm
With chute	21 in	53 cm

Unloading Heights							
Dual	Fixed Incline	2'	3'	4'	5'	6'	7'
28"	36"	41"	49"	54"	60"	65"	70"

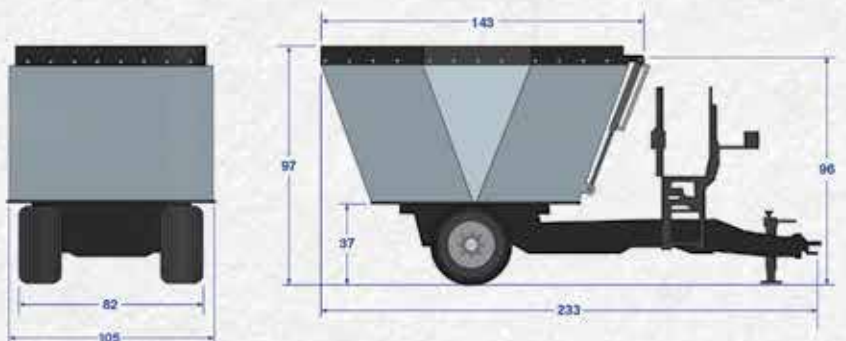



4130

Specifications	Imperial	Metric
Capacity 9" Rubber	425 cu ft	12 m ³
Minimum Horsepower	75 HP	-
Total Width	101 in	257 cm
Total Length	231 in	587 cm
Total Height	105 in	267 cm
Loading Height	100 in	254 cm
Empty Weight	9,922 lbs	4,501 kg

Corner Door Unloading Height	Imperial	Metric
Without chute	26 in	66 cm
With chute	21 in	53 cm

Unloading Heights							
Dual	Fixed Incline	2'	3'	4'	5'	6'	7'
28"	36"	41"	49"	54"	60"	65"	70"

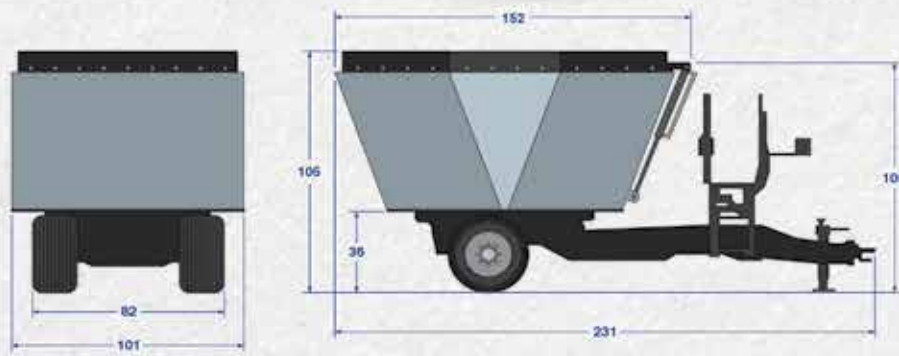

4930

Specifications	Imperial	Metric
Capacity 9" Rubber	480 cu ft	14 m ³
Minimum Horsepower	95 HP	-
Total Width	105 in	267 cm
Total Length	236 in	599 cm
Total Height	105 in	267 cm
Loading Height	104 in	264 cm
Empty Weight	11,000 lbs	4,990 kg

Corner Door Unloading Height	Imperial	Metric
Without chute	26 in	66 cm
With chute	21 in	53 cm

Unloading Heights							
Dual	Fixed Incline	2'	3'	4'	5'	6'	7'
28"	36"	41"	49"	54"	60"	65"	70"

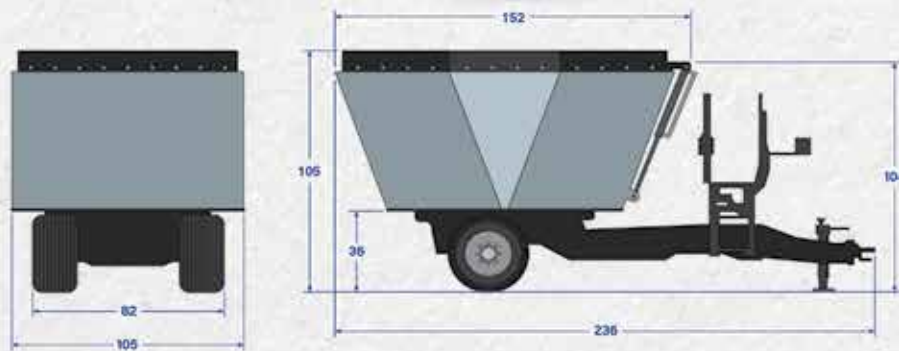

SINGLE AUGER

5030



Specifications	Imperial	Metric
Capacity 9" Rubber	505 cu ft	14 m ³
Minimum Horsepower	85 HP	-
Total Width	101 in	257 cm
Total Length	233 in	592 cm
Total Height	115 in	292 cm
Loading Height	110 in	279 cm
Empty Weight	10,922 lbs	4,954 kg

Corner Door Unloading Height	Imperial	Metric
Without chute	26 in	66 cm
With chute	21 in	53 cm

Unloading Heights							
Dual	Fixed Incline	2'	3'	4'	5'	6'	7'
28"	36"	41"	49"	54"	60"	65"	70"

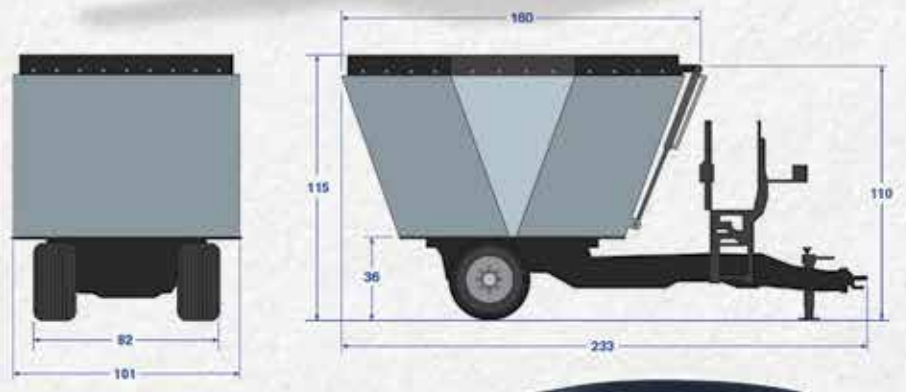

5930



Specifications	Imperial	Metric
Capacity 9" Rubber	605 cu ft	17 m ³
Minimum Horsepower	110 HP	-
Total Width	101 in	257 cm
Total Length	238 in	605 cm
Total Height	126 in	320 cm
Loading Height	121 in	307 cm
Empty Weight	11,176 lbs	5,069 kg

Corner Door Unloading Height	Imperial	Metric
Without chute	26 in	66 cm
With chute	21 in	53 cm

Unloading Heights							
Dual	Fixed Incline	2'	3'	4'	5'	6'	7'
28"	36"	41"	49"	54"	60"	65"	70"

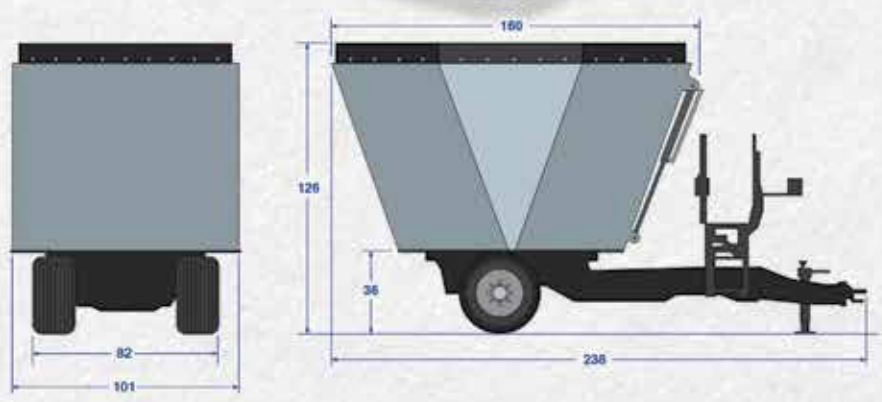

DOUBLE AUGER



4430

Specifications	Imperial	Metric
Capacity 9" Rubber	440 cu ft	12 m ³
Minimum Horsepower	85 HP	-
Total Width	78 in	198 cm
Total Length	274 in	696 cm
Total Height	98 in	264 cm
Loading Height	99 in	251 cm
Empty Weight	13,467 lbs	6,108 kg

Corner Door Unloading Height	Imperial	Metric
Without chute	26 in	66 cm
With chute	21 in	53 cm

Unloading Heights							
Dual	Fixed Incline	2'	3'	4'	5'	6'	7'
28"	36"	41"	49"	54"	60"	65"	70"



6030

Specifications	Imperial	Metric
Capacity 9" Rubber	560 cu ft	17 m ³
Minimum Horsepower	105 HP	-
Total Width	92 in	198 cm
Total Length	309 in	785 cm
Total Height	102 in	259 cm
Loading Height	97 in	246 cm
Empty Weight	15,334 lbs	6,955 kg

Corner Door Unloading Height	Imperial	Metric
Without chute	40 in	76 cm
With chute	29.5 in	64 cm

Unloading Heights							
Dual	Fixed Incline	2'	3'	4'	5'	6'	7'
37.5"	45.5"	50.5"	59"	64"	69"	75"	80"

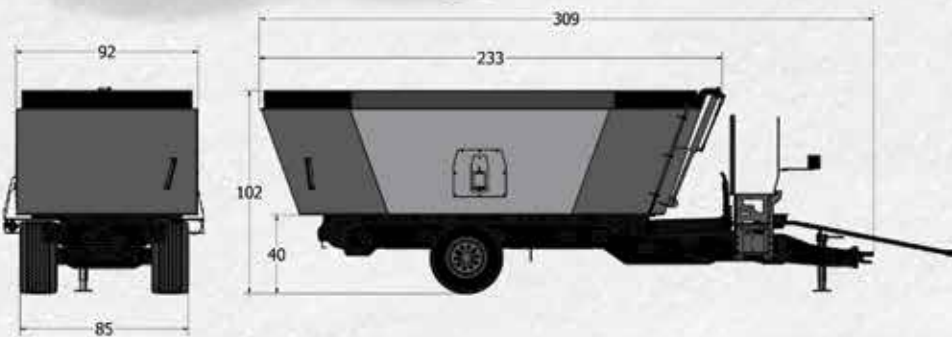



DESIGN TO OPTIMIZE PRODUCTIVITY ROBUST EQUIPMENT TO OPTIMIZE

DOUBLE AUGER

6730



Specifications	Imperial	Metric
Capacity 9" Rubber	640 cu ft	18 m ³
Minimum Horsepower	125 HP	-
Total Width	92 in	198 cm
Total Length	312 in	696 cm
Total Height	107 in	259 cm
Loading Height	102 in	259 cm
Empty Weight	15,334 lbs	6,955 kg

Corner Door Unloading Height	Imperial	Metric
Without chute	30 in	76 cm
With chute	25 in	64 cm

Unloading Heights							
Dual	Fixed Incline	2'	3'	4'	5'	6'	7'
33"	41"	46"	54"	59"	65"	70"	75"



Tandem and Single Axle options available.

8030



Specifications	Imperial	Metric
Capacity 9" Rubber	780 cu ft	23 m ³
Minimum Horsepower	140 HP	-
Total Width	101 in	257 cm
Total Length	329 in	836 cm
Total Height	111 in	282 cm
Loading Height	114 in	269 cm
Empty Weight	22,250 lbs	10,092 kg

Corner Door Unloading Height	Imperial	Metric
Without chute	31 in	79 cm
With chute	26 in	66 cm

Unloading Heights							
Dual	Fixed Incline	2'	3'	4'	5'	6'	7'
34"	42"	47"	55"	60"	66"	71"	76"



Tandem and Single Axle options available.

DOUBLE AUGER



9630

Specifications	Imperial	Metric
Capacity 9" Rubber	925 cu ft	27 m ³
Minimum Horsepower	180 HP	-
Total Width	101 in	257 cm
Total Length	333 in	846 cm
Total Height	119 in	302 cm
Loading Height	114 in	289 cm
Empty Weight	23,547 lbs	10,680 kg



Corner Door Unloading Height	Imperial	Metric
Without chute	31 in	79 cm
With chute	26 in	66 cm

Unloading Heights							
Dual	Fixed Incline	2'	3'	4'	5'	6'	7'
34"	42"	47"	55"	60"	66"	71"	76"



1130

Specifications	Imperial	Metric
Capacity 9" Rubber	1090 cu ft	32 m ³
Minimum Horsepower	200 HP	-
Total Width	101 in	257 cm
Total Length	337 in	856 cm
Total Height	130 in	330 cm
Loading Height	125 in	318 cm
Empty Weight	24,596 lbs	11,157 kg

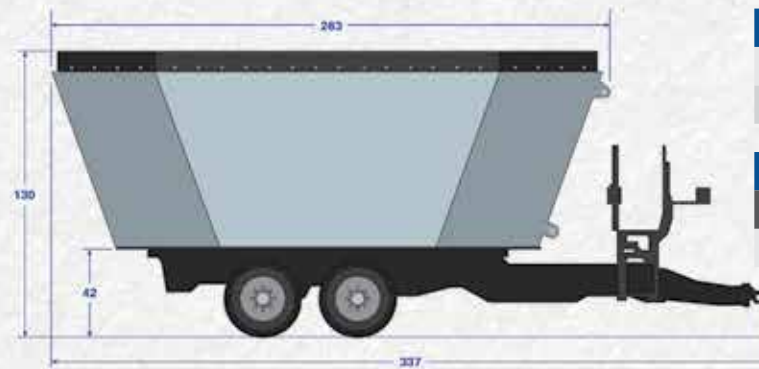
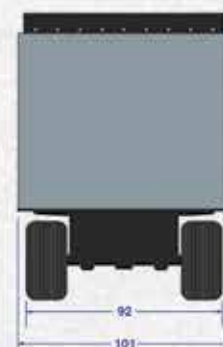

Corner Door Unloading Height	Imperial	Metric
Without chute	31 in	79 cm
With chute	26 in	66 cm

Unloading Heights							
Dual	Fixed Incline	2'	3'	4'	5'	6'	7'
34"	42"	47"	55"	60"	66"	71"	76"

DOUBLE AUGER

1330



Specifications	Imperial	Metric
Capacity 9" Rubber	1300 cu ft	38 m ³
Minimum Horsepower	225 HP	-
Total Width	101 in	257 cm
Total Length	345 in	856 cm
Total Height	144 in	343 cm
Loading Height	139 in	356 cm
Empty Weight	26,345 lbs	11,949 kg

Corner Door Unloading Height	Imperial	Metric
Without chute	31 in	79 cm
With chute	26 in	66 cm

Unloading Heights							
Dual	Fixed Incline	2'	3'	4'	5'	6'	7'
34"	42"	47"	55"	60"	66"	71"	76"

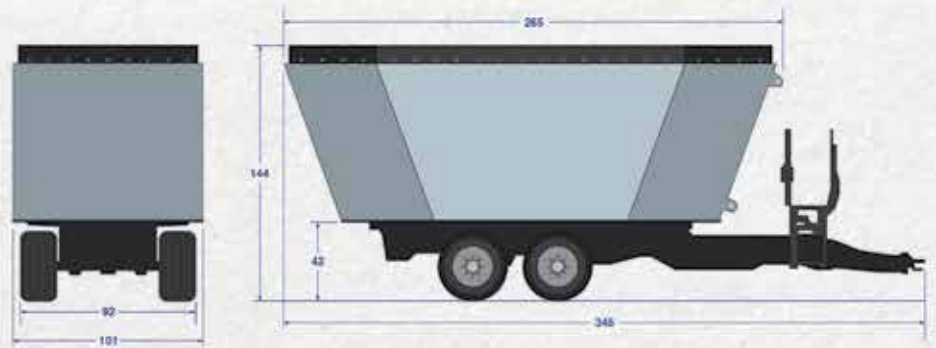

TRIPLE AUGER

1630



Specifications	Imperial	Metric
Capacity 9" Rubber	1580 cu ft	47 m ³
Minimum Horsepower	250 HP	-
Total Width	101 in	257 cm
Total Length	364 in	925 cm
Total Height	135 in	343 cm
Loading Height	130 in	330 cm
Empty Weight	-	-

Corner Door Unloading Height	Imperial	Metric
Without chute	31 in	79 cm
With chute	26 in	66 cm

Unloading Heights							
Dual	Fixed Incline	2'	3'	4'	5'	6'	7'
33"	41"	46"	54"	59"	65"	70"	75"



STATIONARY MIXERS

Penta Stationary Vertical Mixers are compact and convenient machines with a high capacity and low power consumption. Stationary Mixers offer the possibility to use more economical feed boxes with less horsepower to distribute the feed. The mixers run at a reduced constant RPM as opposed to mobile mixers, and full clean out can be arranged through a variable drive and gearbox. All mixers are built on a subframe and supports can be ordered to put the machine at the desired height. The machine is operated by a frequency changer which makes sure that the machine starts slowly and without any increase in power. The frequency changer also enables acceleration as required. Contact Penta for door location and HP requirements.

Model Descriptions	2030	3030	4130	5030	5930	4430	6730
Auger Thickness (Optional 3/4")	1/2"	1/2"	1/2"	1/2"	1/2"	1/2"	1/2"
Floor Thickness	1/2"	3/4"	3/4"	3/4"	3/4"	3/4"	3/4"
2-Speed Gearbox	Standard	Standard	Standard	Standard	Standard	Standard	Standard
Max lbs of Feed in Mixer	4,390 lbs	6,390 lbs	7,650 lbs	9,090 lbs	10,890 lbs	7,920 lbs	11,340 lbs
Magnets	Optional	Optional	Optional	Optional	Optional	Optional	Optional
Electric Door Actuator	Yes	Yes	Yes	Yes	Yes	Yes	Yes



STATIONARY DRIVE SYSTEMS AND ELECTRICAL REQUIREMENTS

Mixer	Drive Style	Electrical Requirements
2030	Belts, 2x10hp	240V single phase, 100A
3030	Belts, 1x20hp	240V single phase, 100A
	Direct, 30hp	240V single phase, 150A 480V three phase, 45A 600V three phase, 35A
4130	Direct, 40hp	240V single phase, 200A 480V three phase, 70A 600V three phase, 50A
	Direct, 50hp	240V single phase, 225A 480V three phase, 80A 600V three phase, 60A

Mixer	Drive Style	Electrical Requirements
5030	Direct, 40hp	240V single phase, 200A 480V three phase, 70A 600V three phase, 50A
	Direct, 50hp	240V single phase, 225A 480V three phase, 80A 600V three phase, 60A
5930	Direct, 50hp	240V single phase, 225A 480V three phase, 80A 600V three phase, 60A
	Direct, 60hp	480V three phase, 90A 600V three phase, 70A

Mixer	Drive Style	Electrical Requirements
4430	Belts, 2x15hp	240V single phase, 150A 240V single phase, 200A
	Direct, 40hp	480V single phase, 45A 600V three phase, 35A
6730	Direct, 50hp	240V single phase, 225A 480V three phase, 80A 600V three phase, 60A
	Direct, 60hp	480V three phase, 90A 600V three phase, 70A

STATIONARY MIXER FEATURES



ELECTRONIC CONTROLS

The mixers are able to run at a reduced constant RPM using electronic controls.

- Variable Speed Drive allows the mixer:
 - soft starting
 - easy speed control
 - momentary reverse button
 - slow down
- Remote Door Controls

DRIVELINE

To transfer electric power to the mixer there are a variety of ways to use a single motor or motors together.

Drives offered:

- Belt Drives - optional
- Direct Drives
- PTO Drive
- 2 Speed Gear Box



DOORS

There are two door options available for the stationary mixer. Each stationary mixer can be customized and multiple door options are available on a single unit.

Placement options:

- End Doors
- Corner Doors



CONVEYOR

Conveyors for the stationary mixer come in 3 size options and are built for long life and dependability using the heaviest cast chain in the industry.

- Available sizes: Bases 4.5' - 5' - 6' - 7', Wings 9' - 10' - 12'
- Powered by Electric 3 HP Motor

2030

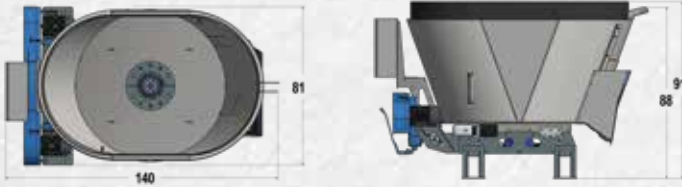

Specifications	Imperial	Metric
Capacity 9" Rubber	244 cu ft	7m ³
Total Width	81 in	206 cm
Total Length	140 in	355.6 cm
Total Height	91 in	231 cm
Loading Height	88 in	224 cm
Chute Height	17 in	43 cm

3030

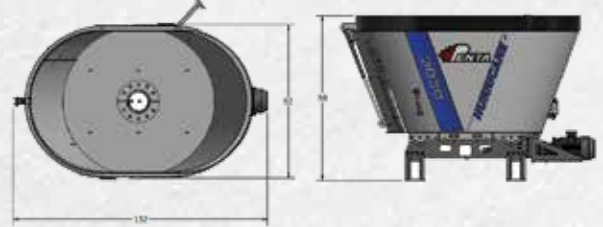

Specifications	Imperial	Metric
Capacity 9" Rubber	355 cu ft	10m ³
Total Width	92 in	234 cm
Total Length	152 in	386 cm
Total Height	98 in	248 cm
Loading Height	93 in	236 cm
Chute Height	17 in	42 cm

4130

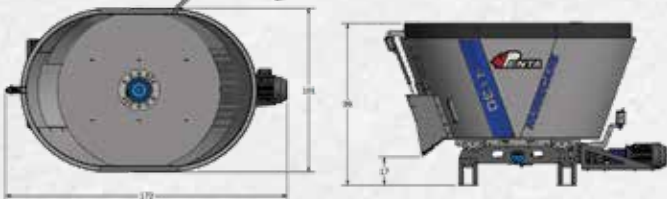

Specifications	Imperial	Metric
Capacity 9" Rubber	425 cu ft	12m ³
Total Width	101 in	256 cm
Total Length	172 in	437 cm
Total Height	99 in	251 cm
Loading Height	94 in	238 cm
Chute Height	17 in	42 cm

5030

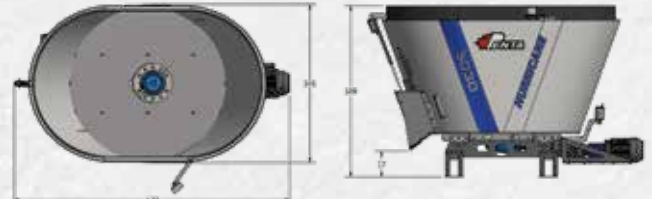

Specifications	Imperial	Metric
Capacity 9" Rubber	505 cu ft	14m ³
Total Width	101 in	256 cm
Total Length	177 in	450 cm
Total Height	109 in	278 cm
Loading Height	104 in	265 cm
Chute Height	17 in	43 cm

5930

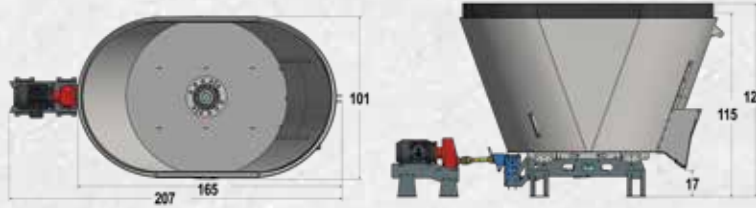

Specifications	Imperial	Metric
Capacity 9" Rubber	605 cu ft	17m ³
Total Width	101 in	256 cm
Total Length	207 in	526 cm
Total Height	121 in	307 cm
Loading Height	115 in	291 cm
Chute Height	17 in	42 cm

4430

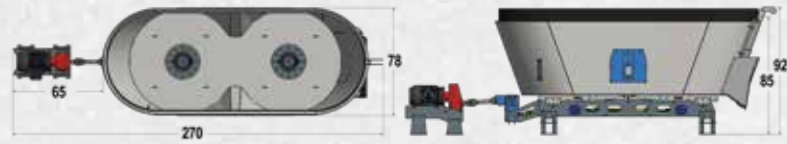

Specifications	Imperial	Metric
Capacity 9" Rubber	440 cu ft	12m ³
Total Width	78 in	198 cm
Total Length	270 in	685 cm
Total Height	92 in	234 cm
Loading Height	85 in	215 cm
Chute Height	17 in	44 cm

6730

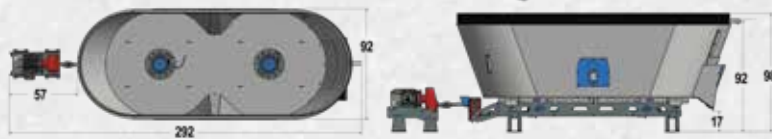

Specifications	Imperial	Metric
Capacity 9" Rubber	630 cu ft	18m ³
Total Width	92 in	233 cm
Total Length	292 in	742 cm
Total Height	98 in	250 cm
Loading Height	92 in	234 cm
Chute Height	17 in	44 cm



TRUCK MOUNT MIXERS

HIGH SPEED DELIVERY

Penta Truck Mount Mixers are specially designed to suit the needs of larger operations, or applications where rough terrain and/or longer distances are encountered. All Penta Truck Mount models are 100% hydrostatically driven. There are no gearbox, sprockets, belts, chains or bearings in the driveline to wear out and require replacement. Fewer moving parts translates into fewer breakdowns and less maintenance overall. It means that operators will have faster than average mixing times, and the capacity to process different forage components and micro ingredients with a maximum efficiency.



8030 Truck Mounted Mixer



TRUCK MOUNT MIXER FEATURES



CONTROLS

- Digital Screen
- Joystick
- Oil Temperature Monitor
- Oil Pressure Monitor
- Optional Cameras



CONVEYOR

Conveyors are configured to match the individual needs of the operator.

- Dog Leg System
- Slide Out Conveyors
- Designed to be Grain Ration Ready



TUB & AUGER

The angled curve of the tub and baffles are designed to work with our Hurricane augers for the best mix possible and provides easy clean out.

- Stainless Steel Tub Liner included in the truck mount mixers increases the longevity of the life of the tub
- Massive front and rear material doors increase efficiency in unloading and clean out

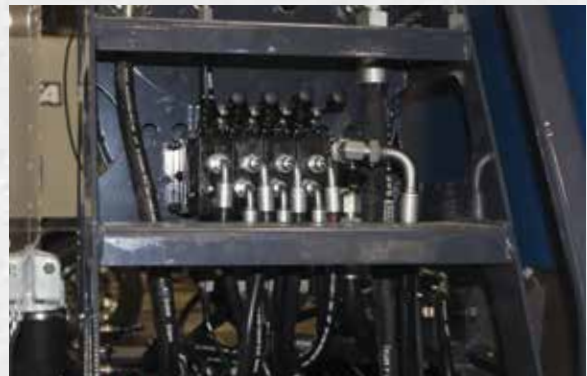

DRIVE SYSTEM

- Hydraulic Pumps (Dan Foss)
- Radial Piston Motors (Poclain)
- Upgrade to the "Prowler System" for the ability to drive the truck hydrostatically and in regular highway mode

TRUCK MOUNT SPECS

6730

Specifications	Imperial	Metric
Capacity 9" Rubber	630 cu ft	18m ³
Total Width	92 in	198 cm
Total Length	312 in	696 cm
Empty Weight	15,334 lbs	6,955 kg

7130

Specifications	Imperial	Metric
Capacity 9" Rubber	672 cu ft	19m ³
Total Width	95 in	241 cm
Total Length	318 in	808 cm
Empty Weight	15,334 lbs	6,955 kg

8030

Specifications	Imperial	Metric
Capacity 9" Rubber	820 cu ft	23 m ³
Total Width	101 in	257 cm
Total Length	329 in	836 cm
Empty Weight	22,250 lbs	10,092 kg

9630

Specifications	Imperial	Metric
Capacity 9" Rubber	965 cu ft	27 m ³
Total Width	101 in	257 cm
Total Length	333 in	846 cm
Empty Weight	23,547 lbs	10,680 kg

1130

Specifications	Imperial	Metric
Capacity 9" Rubber	1,130 cu ft	32 m ³
Total Width	101 in	257 cm
Total Length	337 in	856 cm
Empty Weight	24,596 lbs	11,157 kg

9830

Specifications	Imperial	Metric
Capacity 9" Rubber	1,006 cu ft	28 m ³
Total Bottom Width	103.5 in	262.9 cm
Total Top Width	120.75 in	306.7 cm
Total Length	254 in	645.2 cm
Empty Weight	21,500 lbs	9,752 kg

TRUCK REQUIREMENTS

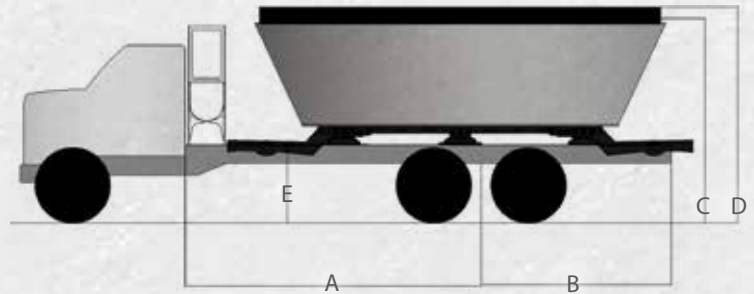

MODEL	HP	Front Axle	Rear Axle	Preferred Transmission	Cab to Axle (A)	End of Frame (B)	Overall Height (C)	Approximate Overall Height w/ rubber (D)	Conveyor Clearance ¹ (E)	Corner Door
6730	325- 350	16,000 lbs	40,000 lbs	Allison 3500RDS	150"	84"	118"	124"	44"	25"
7130	325- 350	16,000 lbs	40,000 lbs	Allison 3500RDS	150"	90"	118"	124"	44"	25"
8030	350 - 400	16,000 lbs	46,000 lbs	Allison 4700RDS	175"	96"	120"	126"	44"	26"
9630	425 - 475	20,000 lbs	46,000 lbs	Allison 4700RDS	175"	96"	130"	136"	44"	26"
1130	425 - 475	20,000 lbs	46,000 lbs	Allison 4700RDS	175"	96"	142"	148"	44"	26"
9830	400	20,000 lbs	46,000 lbs	Allison 4500RDS or 4700RDS	177.75"	76.25"	125"	131"	42.25"	26"

Unloading Heights

Dual	Fixed Incline	3'
44"	52"	65"

*Standard trucks are Peterbilt and Western Star.

*Add \$4000 for other truck brands.

¹ Measurement based on North American truck configuration - subject to change.

FIELD TO FARM TO FIELD



FEED WITH

FROM FIELD TO FARM

The Penta Dump Trailers are designed to get your crop from the field to your farm. Ranging in size from 1050 cubic feet to 2475 cubic feet there is one ready for you.

Farmer focused features like better visibility in the box and the unique reverse tilt for better filling, are built as tough as you are.

FARM FEEDING

The best quality feed needs the best quality mix. Penta TMR mixers are designed, tested and farm proven to deliver the best mix on the market. Our Hurricane auger allows forage to circulate faster through the mix for quicker processing and mixing times.

FROM FARM TO FIELD

The Penta (Hagedorn) line of manure spreaders allows you to make the best use of your organic nutrient resources. The Hagedorn processes the manure finer and delivers the best spread pattern. This lets your field make the best use of this rich resource.

888-844-7788

FOLLOW US ON SOCIAL MEDIA

 @pentafarmequip
 @PentaFarmEquip

www.pentaequipment.com